

**PRODUCT CODE: EWS6-26**  
SWITCH & SOCKET BOX

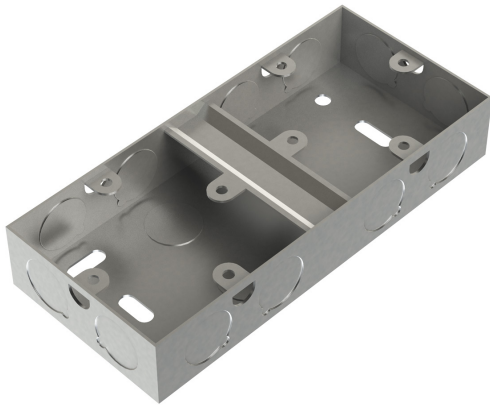

**DESCRIPTION**

25mm Dual Box Switch & Socket Box

**FINISH**

Pre Galvanised

**MATERIAL**

Sheet steel to comply with BS4662

**PACKAGING**

Packed in qty 5

**ADDITIONAL NOTES**

Comprises body and earth terminal with screw  
7 fixed lugs and 2 adjustable lugs, 20mm Knockouts  
Compliant to BS4662 & LU Standard 1-085 (for use on surface & sub-surface locations)

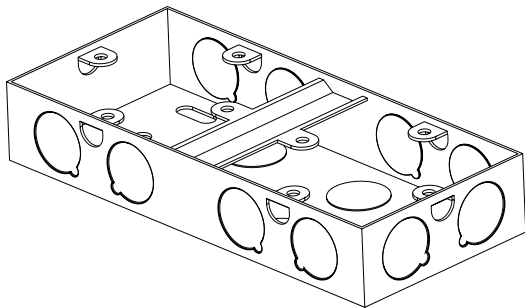

Isometric view

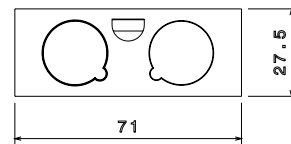

Front view

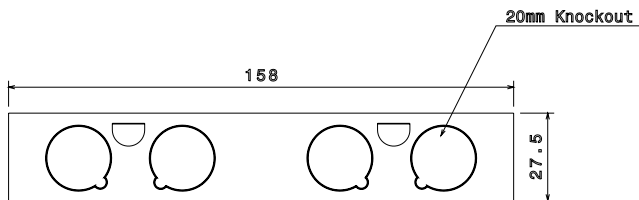

Side view

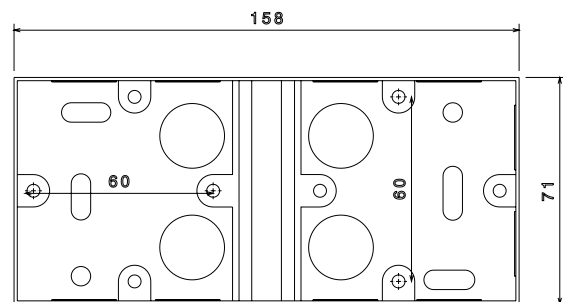

Top view